

6A SIMPLE SWITCHER® Power Module with 2.95V-6V Input in QFN Package

Check for Samples: [LMZ30606](#)

FEATURES

- Complete Integrated Power Solution Allows Small Footprint, Low-Profile Design
- 9mm x 11mm x 2.8mm package
- Pin Compatible with LMZ30602 & LMZ30604
- Efficiencies Up To 96%
- Wide-Output Voltage Adjust
0.8 V to 3.6 V, with $\pm 1\%$ Reference Accuracy
- Adjustable Switching Frequency
(500 kHz to 2 MHz)
- Synchronizes to an External Clock
- Adjustable Slow-Start
- Output Voltage Sequencing / Tracking
- Power Good Output
- Programmable Undervoltage Lockout (UVLO)
- Output Overcurrent Protection
- Over Temperature Protection
- Operating Temperature Range: -40°C to 85°C
- Enhanced Thermal Performance: 12°C/W
- Meets EN55022 Class B Emissions
- Integrated Shielded Inductor

APPLICATIONS

- Broadband and Communications Infrastructure
- Automated Test and Medical Equipment
- Compact PCI / PCI Express / PXI Express
- DSP and FPGA Point of Load Applications
- High Density Distributed Power Systems

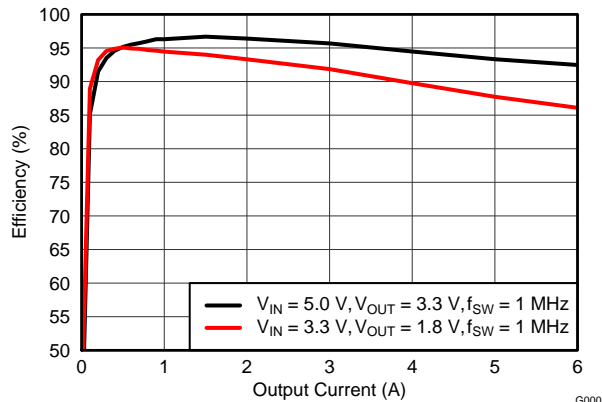

DESCRIPTION

The LMZ30606 SIMPLE SWITCHER® power module is an easy-to-use integrated power solution that combines a 6-A DC/DC converter with power MOSFETs, a shielded inductor, and passives into a low profile, QFN package. This total power solution requires as few as 3 external components and eliminates the loop compensation and magnetics part selection process.

The 9x11x2.8 mm QFN package is easy to solder onto a printed circuit board and allows a compact point-of-load design with greater than 90% efficiency and excellent power dissipation with a thermal impedance of 12°C/W junction to ambient. The device delivers the full 6-A rated output current at 85°C ambient temperature without airflow.

The LMZ30606 offers the flexibility and the feature-set of a discrete point-of-load design and is ideal for powering performance DSPs and FPGAs. Advanced packaging technology afford a robust and reliable power solution compatible with standard QFN mounting and testing techniques.

SIMPLIFIED APPLICATION

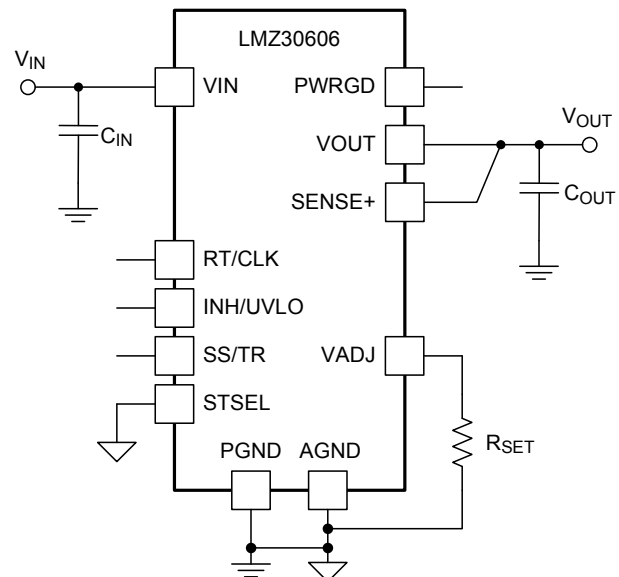

Please be aware that an important notice concerning availability, standard warranty, and use in critical applications of Texas Instruments semiconductor products and disclaimers thereto appears at the end of this data sheet.

SIMPLE SWITCHER is a registered trademark of Texas Instruments.



This integrated circuit can be damaged by ESD. Texas Instruments recommends that all integrated circuits be handled with appropriate precautions. Failure to observe proper handling and installation procedures can cause damage.

ESD damage can range from subtle performance degradation to complete device failure. Precision integrated circuits may be more susceptible to damage because very small parametric changes could cause the device not to meet its published specifications.

ORDERING INFORMATION

For the most current package and ordering information, see the Package Option Addendum at the end of this datasheet, or see the TI website at www.ti.com.

ABSOLUTE MAXIMUM RATINGS⁽¹⁾ over operating temperature range (unless otherwise noted)

		VALUE		UNIT
		MIN	MAX	
Input Voltage	VIN, PWRGD	-0.3	7	V
	INH/UVLO, RT/CLK	-0.3	3.3	V
	SS/TR, STSEL, VADJ	-0.3	3	V
	SENSE+ VADJ rating must also be met	-0.3	V _{OUT}	V
Output Voltage	PH	-0.6	7	V
	PH 10 ns, transient	-2	7	V
	VOUT	-0.6	VIN	V
V _{DIFF} (GND to exposed thermal pad)		-0.2	0.2	V
Source Current	RT/CLK, INH/UVLO		±100	µA
	PH		Current Limit	A
Sink Current	PH		Current Limit	A
	SS/TR		±100	µA
	PWRGD		10	mA
Operating Junction Temperature		-40	125 ⁽²⁾	°C
Storage Temperature, T _{stg}		-65	150	°C
Mechanical Shock	Mil-STD-883D, Method 2002.3, 1 msec, 1/2 sine, mounted		1500	G
Mechanical Vibration	Mil-STD-883D, Method 2007.2, 20-2000Hz		20	

- (1) Stresses beyond those listed under absolute maximum ratings may cause permanent damage to the device. These are stress ratings only, and functional operation of the device at these or any other conditions beyond those indicated under recommended operating conditions is not implied. Exposure to absolute-maximum-rated conditions for extended periods may affect device reliability.
- (2) See the temperature derating curves in the Typical Characteristics section for thermal information.

THERMAL INFORMATION

THERMAL METRIC ⁽¹⁾		LMZ30606	UNIT
		RKG39	
		39 PINS	
θ _{JA}	Junction-to-ambient thermal resistance ⁽²⁾	12	°C/W
ψ _{JT}	Junction-to-top characterization parameter ⁽³⁾	2.2	
ψ _{JB}	Junction-to-board characterization parameter ⁽⁴⁾	9.7	

- (1) For more information about traditional and new thermal metrics, see the IC Package Thermal Metrics application report, [SPRA953](#).
- (2) The junction-to-ambient thermal resistance, θ_{JA}, applies to devices soldered directly to a 100 mm x 100 mm double-sided PCB with 1 oz. copper and natural convection cooling. Additional airflow reduces θ_{JA}.
- (3) The junction-to-top characterization parameter, ψ_{JT}, estimates the junction temperature, T_J, of a device in a real system, using a procedure described in JESD51-2A (sections 6 and 7). T_J = ψ_{JT} * P_{dis} + T_T; where P_{dis} is the power dissipated in the device and T_T is the temperature of the top of the device.
- (4) The junction-to-board characterization parameter, ψ_{JB}, estimates the junction temperature, T_J, of a device in a real system, using a procedure described in JESD51-2A (sections 6 and 7). T_J = ψ_{JB} * P_{dis} + T_B; where P_{dis} is the power dissipated in the device and T_B is the temperature of the board 1mm from the device.

ELECTRICAL CHARACTERISTICS

Over -40°C to 85°C free-air temperature, $V_{IN} = 3.3\text{ V}$, $V_{OUT} = 1.8\text{ V}$, $I_{OUT} = 6\text{ A}$,
 $C_{IN1} = 47\text{ }\mu\text{F}$ ceramic, $C_{IN2} = 220\text{ }\mu\text{F}$ poly-tantalum, $C_{OUT1} = 47\text{ }\mu\text{F}$ ceramic, $C_{OUT2} = 100\text{ }\mu\text{F}$ poly-tantalum (unless otherwise noted)

PARAMETER		TEST CONDITIONS	MIN	TYP	MAX	UNIT	
I_{OUT}	Output current	$T_A = 85^\circ\text{C}$, natural convection	0		6	A	
V_{IN}	Input voltage range	Over I_{OUT} range	2.95 ⁽¹⁾		6	V	
UVLO	VIN Undervoltage lockout	VIN = increasing		3.05	3.135	V	
		VIN = decreasing	2.5	2.75			
$V_{OUT(adj)}$	Output voltage adjust range	Over I_{OUT} range	0.8		3.6	V	
V_{OUT}	Set-point voltage tolerance	$T_A = 25^\circ\text{C}$, $I_{OUT} = 0\text{ A}$			$\pm 1.0\%$ ⁽²⁾		
	Temperature variation	$-40^\circ\text{C} \leq T_A \leq +85^\circ\text{C}$, $I_{OUT} = 0\text{ A}$		$\pm 0.3\%$			
	Line regulation	Over VIN range, $T_A = 25^\circ\text{C}$, $I_{OUT} = 0\text{ A}$		$\pm 0.1\%$			
	Load regulation	Over I_{OUT} range, $T_A = 25^\circ\text{C}$		$\pm 0.1\%$			
	Total output voltage variation	Includes set-point, line, load, and temperature variation				$\pm 1.5\%$ ⁽²⁾	
η	Efficiency	$V_{IN} = 5\text{ V}$ $I_O = 3\text{ A}$	$V_{OUT} = 3.3\text{ V}$, $f_{SW} = 1\text{ MHz}$		96%		
			$V_{OUT} = 2.5\text{ V}$, $f_{SW} = 1\text{ MHz}$		94%		
			$V_{OUT} = 1.8\text{ V}$, $f_{SW} = 1\text{ MHz}$		92%		
			$V_{OUT} = 1.5\text{ V}$, $f_{SW} = 1\text{ MHz}$		90%		
			$V_{OUT} = 1.2\text{ V}$, $f_{SW} = 750\text{ kHz}$		89%		
			$V_{OUT} = 1.0\text{ V}$, $f_{SW} = 650\text{ kHz}$		87%		
		$V_{IN} = 3.3\text{ V}$ $I_O = 3\text{ A}$	$V_{OUT} = 0.8\text{ V}$, $f_{SW} = 650\text{ kHz}$		85%		
			$V_{OUT} = 1.8\text{ V}$, $f_{SW} = 1\text{ MHz}$		92%		
			$V_{OUT} = 1.5\text{ V}$, $f_{SW} = 1\text{ MHz}$		90%		
			$V_{OUT} = 1.2\text{ V}$, $f_{SW} = 750\text{ kHz}$		89%		
			$V_{OUT} = 1.0\text{ V}$, $f_{SW} = 650\text{ kHz}$		87%		
			$V_{OUT} = 0.8\text{ V}$, $f_{SW} = 650\text{ kHz}$		85%		
	Output voltage ripple	20 MHz bandwidth		10		mV _{PP}	
I_{LIM}	Overcurrent threshold			9		A	
	Transient response	1.0 A/ μs load step from 1.5A to 4.5A	Recovery time		80	μs	
			V_{OUT} over/undershoot		120	mV	
V_{INH-H}	Inhibit Control	Inhibit High Voltage		1.25	Open ⁽³⁾	V	
V_{INH-L}		Inhibit Low Voltage	-0.3	1.0			
$I_{I(stby)}$	Input standby current	INH pin to AGND		70	100	μA	
Power Good	PWRGD Thresholds	V_{OUT} rising	Good		93%		
			Fault		109%		
		V_{OUT} falling	Fault		91%		
			Good		107%		
	PWRGD Low Voltage	$I(\text{PWRGD}) = 0.33\text{ mA}$			0.3	V	
f_{SW}	Switching frequency	Over VIN and I_{OUT} ranges, RT/CLK pin OPEN	400	500	600	kHz	
f_{CLK}	Synchronization frequency		500		2000	kHz	
V_{CLK-H}	CLK High-Level Threshold	CLK Control		2.2	3.3	V	
V_{CLK-L}	CLK Low-Level Threshold			-0.3	0.4	V	
CLK_PW	CLK Pulse Width			75 ⁽⁴⁾		ns	
	Thermal Shutdown	Thermal shutdown		170		$^\circ\text{C}$	
		Thermal shutdown hysteresis		20		$^\circ\text{C}$	

- (1) The minimum VIN depends on V_{OUT} and the switching frequency. Please refer to [Table 7](#) for operating limits.
- (2) The stated limit of the set-point voltage tolerance includes the tolerance of both the internal voltage reference and the internal adjustment resistor. The overall output voltage tolerance will be affected by the tolerance of the external R_{SET} resistor.
- (3) This control pin has an internal pullup. Do not place an external pull-up resistor on this pin. If this pin is left open circuit, the device operates when input power is applied. A small low-leakage MOSFET is recommended for control. See the application section for further guidance.
- (4) The maximum synchronization clock pulse width is dependant on VIN, V_{OUT} , and the synchronization frequency. See the [Synchronization \(CLK\)](#) section for more information.

ELECTRICAL CHARACTERISTICS (continued)

Over -40°C to 85°C free-air temperature, $V_{\text{IN}} = 3.3\text{ V}$, $V_{\text{OUT}} = 1.8\text{ V}$, $I_{\text{OUT}} = 6\text{ A}$,

$C_{\text{IN}1} = 47\text{ }\mu\text{F}$ ceramic, $C_{\text{IN}2} = 220\text{ }\mu\text{F}$ poly-tantalum, $C_{\text{OUT}1} = 47\text{ }\mu\text{F}$ ceramic, $C_{\text{OUT}2} = 100\text{ }\mu\text{F}$ poly-tantalum (unless otherwise noted)

PARAMETER	TEST CONDITIONS	MIN	TYP	MAX	UNIT
C_{IN} External input capacitance	Ceramic	47 ⁽⁵⁾			μF
	Non-ceramic		220 ⁽⁵⁾		
C_{OUT} External output capacitance	Ceramic	47 ⁽⁶⁾	150	650 ⁽⁷⁾	μF
	Non-ceramic		100 ⁽⁶⁾	2000 ⁽⁷⁾	
	Equivalent series resistance (ESR)				25

- (5) A minimum of $47\mu\text{F}$ of ceramic capacitance is required across the input for proper operation. Locate the capacitor close to the device. An additional $220\mu\text{F}$ of bulk capacitance is recommended. See [Table 4](#) for more details.
- (6) The amount of required output capacitance varies depending on the output voltage (see [Table 3](#)). The amount of required capacitance must include at least $47\mu\text{F}$ of ceramic capacitance. Locate the capacitance close to the device. Adding additional capacitance close to the load improves the response of the regulator to load transients. See [Table 3](#) and [Table 4](#) for more details.
- (7) When using both ceramic and non-ceramic output capacitance, the combined maximum must not exceed $2200\mu\text{F}$.

PACKAGE SPECIFICATIONS

	LMZ30606	UNIT
Weight		0.85 grams
Flammability	Meets UL 94 V-O	
MTBF Calculated reliability	Per Bellcore TR-332, 50% stress, $T_A = 40^{\circ}\text{C}$, ground benign	32.8 Mhrs

DEVICE INFORMATION

FUNCTIONAL BLOCK DIAGRAM

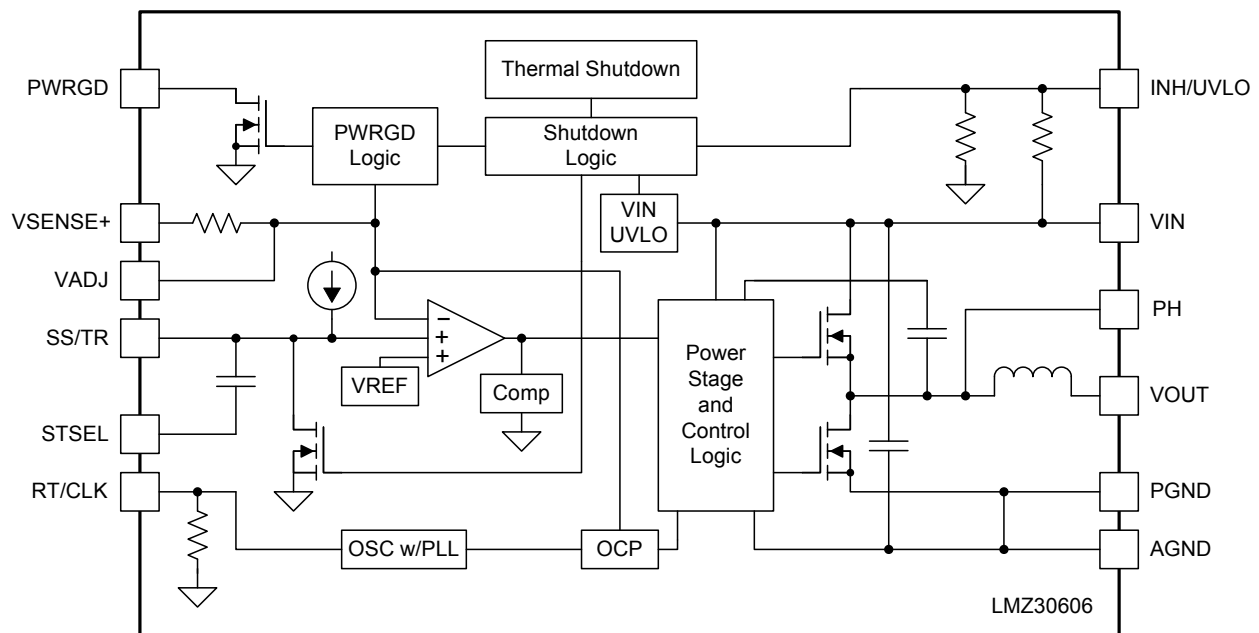

PIN DESCRIPTIONS

TERMINAL		DESCRIPTION
NAME	NO.	
AGND	1	Zero VDC reference for the analog control circuitry. These pins should be connected directly to the PCB analog ground plane. Not all pins are connected together internally. All pins must be connected together externally with a copper plane or pour directly under the module. Connect the AGND copper area to the PGND copper area at a single point; directly at the pin 37 PowerPAD using multiple vias. See the recommended layout in Figure 36 .
	5	
	29	
	33	
	34	
PowerPAD (PGND)	37	This pad provides both an electrical and thermal connection to the PCB. This pad should be connected directly to the PCB power ground plane using multiple vias for good electrical and thermal performance. The same vias should also be used to connect to the PCB analog ground plane. See the recommended layout in Figure 36 .
DNC	2	Do Not Connect. Do not connect these pins to AGND, to another DNC pin, or to any other voltage. These pins are connected to internal circuitry. Each pin must be soldered to an isolated pad.
	3	
	15	
	16	
	26	
INH/UVLO	28	Inhibit and UVLO adjust pin. Use an open drain or open collector output logic to control the INH function. A resistor between this pin and AGND adjusts the UVLO voltage.
PH	17	Phase switch node. These pins should be connected by a small copper island under the device for thermal relief. Do not connect any external component to this pin or tie it to a pin of another function.
	18	
	19	
	20	
	21	
	22	
	23	
	24	
	25	
39		
PWRGD	27	Power good fault pin. Asserts low if the output voltage is out of tolerance. A pull-up resistor is required.
RT/CLK	4	This pin automatically selects between RT mode and CLK mode. An external timing resistor adjusts the switching frequency of the device. In CLK mode, the device synchronizes to an external clock.
SENSE+	36	Remote sense connection. Connect this pin to VOUT at the load for improved regulation. This pin must be connected to VOUT at the load, or at the module pins.
SS/TR	6	Slow-start and tracking pin. Connecting an external capacitor to this pin adjusts the output voltage rise time. A voltage applied to this pin allows for tracking and sequencing control.
STSEL	7	Slow-start or track feature select. Connect this pin to AGND to enable the internal SS capacitor with a SS interval of approximately 1.1 ms. Leave this pin open to enable the TR feature.
VADJ	35	Connecting a resistor between this pin and AGND sets the output voltage above the 0.8V default voltage.
VIN	30	The positive input voltage power pins, which are referenced to PGND. Connect external input capacitance between these pins and the PGND plane, close to the device.
	31	
	32	
VOUT	8	Output voltage. Connect output capacitors between these pins and the PGND plane, close to the device.
	9	
	10	
	11	
	12	
	13	
	14	
38		

RKG PACKAGE
39 PINS
(TOP VIEW)

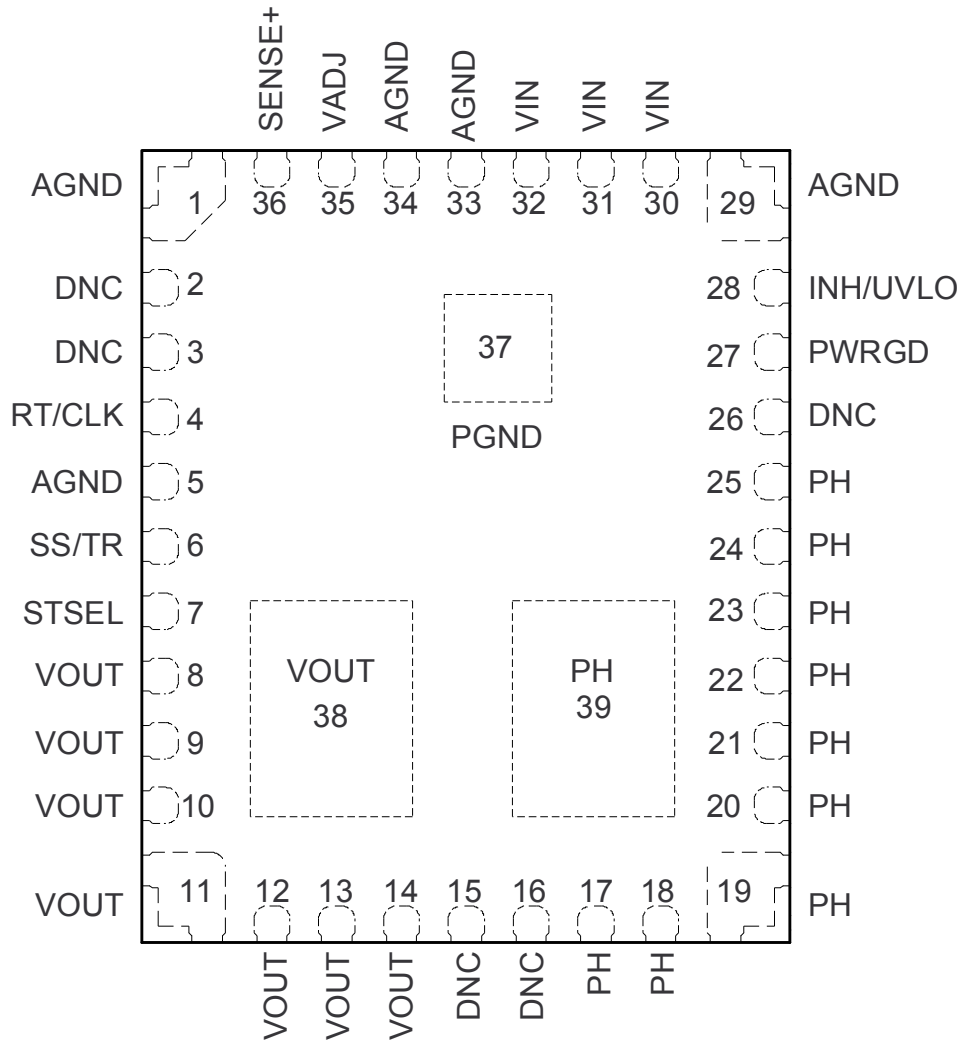

TYPICAL CHARACTERISTICS (VIN = 5 V) (1) (2)

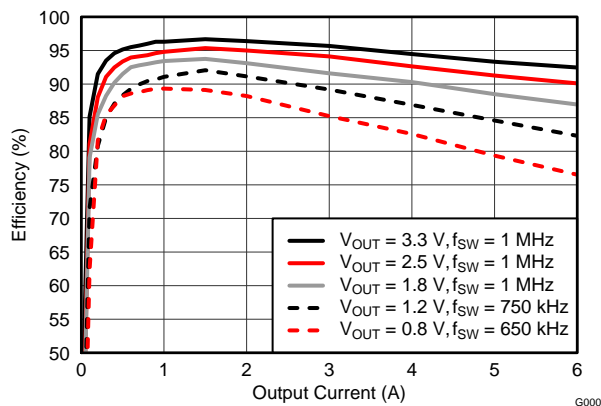

Figure 1. Efficiency vs. Output Current

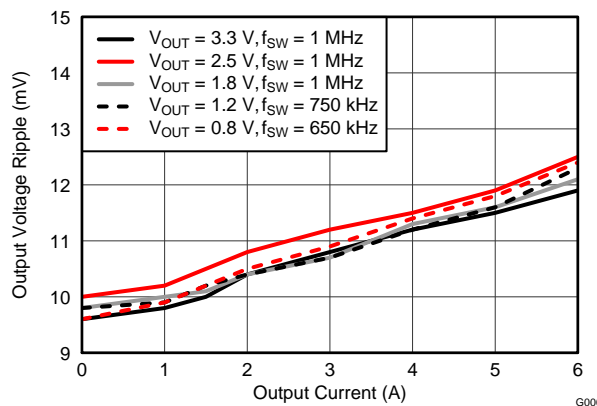

Figure 2. Voltage Ripple vs. Output Current

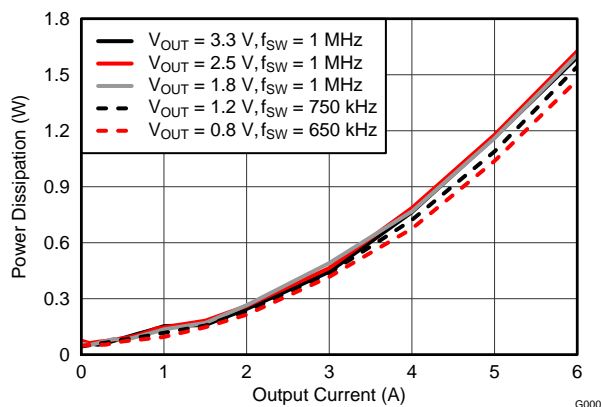

Figure 3. Power Dissipation vs. Output Current

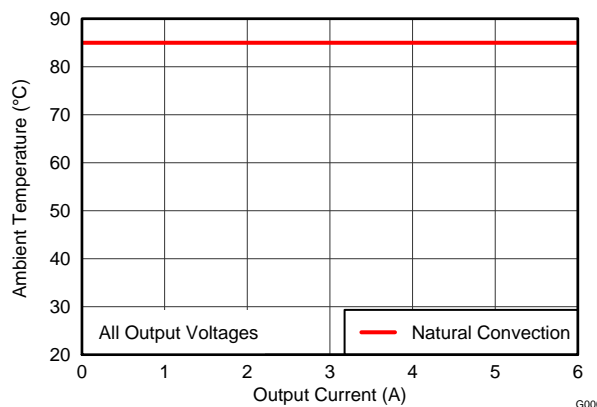

Figure 4. Safe Operating Area

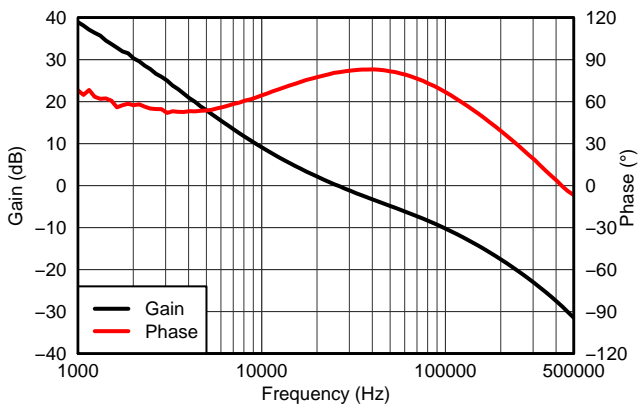

Figure 5. $V_{OUT} = 1.8\text{ V}$, $I_{OUT} = 6\text{ A}$, $C_{OUT1} = 47\text{ }\mu\text{F}$ ceramic, $C_{OUT2} = 100\text{ }\mu\text{F}$ POSCAP, $f_{SW} = 1\text{ MHz}$

- (1) The electrical characteristic data has been developed from actual products tested at 25°C. This data is considered typical for the converter. Applies to Figure 1, Figure 2, and Figure 3.
- (2) The temperature derating curves represent the conditions at which internal components are at or below the manufacturer's maximum operating temperatures. Derating limits apply to devices soldered directly to a 100 mm × 100 mm double-sided PCB with 1 oz. copper. Applies to Figure 4.

TYPICAL CHARACTERISTICS (VIN = 3.3 V) (1) (2)

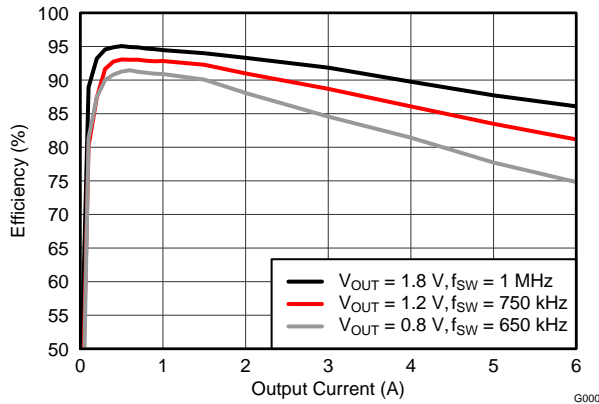

Figure 6. Efficiency vs. Output Current

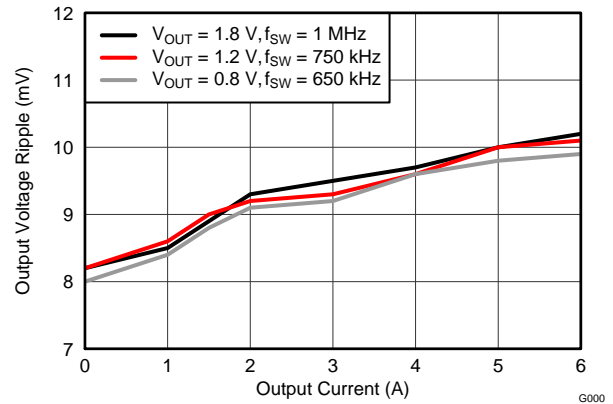

Figure 7. Voltage Ripple vs. Output Current

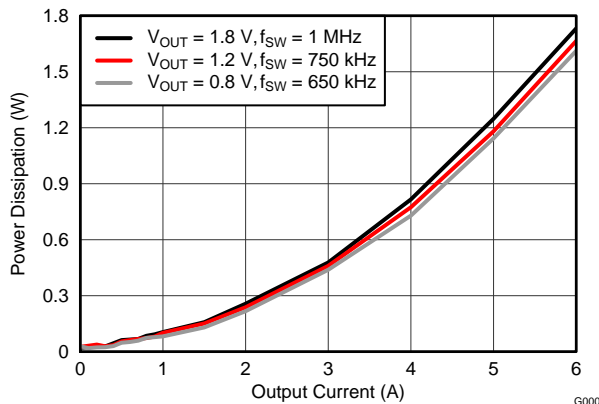

Figure 8. Power Dissipation vs. Output Current

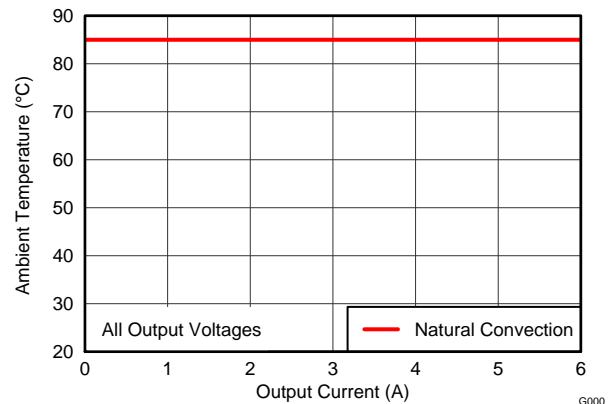

Figure 9. Safe Operating Area

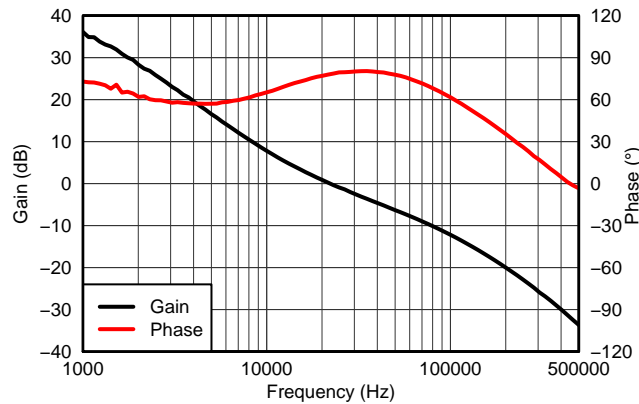

Figure 10. VOUT= 1.8 V, IOUT= 6 A, COUT1= 47 μF ceramic, COUT2= 100 μF POSCAP, fSW= 1 MHz

- (1) The electrical characteristic data has been developed from actual products tested at 25°C. This data is considered typical for the converter. Applies to [Figure 6](#), [Figure 7](#), and [Figure 8](#).
- (2) The temperature derating curves represent the conditions at which internal components are at or below the manufacturer's maximum operating temperatures. Derating limits apply to devices soldered directly to a 100 mm × 100 mm double-sided PCB with 1 oz. copper. Applies to [Figure 9](#).

APPLICATION INFORMATION

ADJUSTING THE OUTPUT VOLTAGE

The V_{ADJ} control sets the output voltage of the LMZ30606. The output voltage adjustment range is from 0.8V to 3.6V. The adjustment method requires the addition of R_{SET}, which sets the output voltage, the connection of SENSE+ to V_{OUT}, and in some cases R_{RT} which sets the switching frequency. The R_{SET} resistor must be connected directly between the V_{ADJ} (pin 35) and AGND (pin 33 & 34). The SENSE+ pin (pin 36) must be connected to V_{OUT} either at the load for improved regulation or at V_{OUT} of the module. The R_{RT} resistor must be connected directly between the RT/CLK (pin 4) and AGND (pins 33 & 34).

Table 1 gives the standard external R_{SET} resistor for a number of common bus voltages, along with the recommended R_{RT} resistor for that output voltage.

Table 1. Standard R_{SET} Resistor Values for Common Output Voltages

RESISTORS	OUTPUT VOLTAGE V _{OUT} (V)					
	0.8	1.2	1.5	1.8	2.5	3.3
R _{SET} (kΩ)	open	2.87	1.65	1.15	0.673	0.459
R _{RT} (kΩ)	1200	715	348	348	348	348

For other output voltages, the value of the required resistor can either be calculated using the following formula, or simply selected from the range of values given in Table 2.

$$R_{SET} = \frac{1.43}{\left(\left(\frac{V_{OUT}}{0.799}\right) - 1\right)} \text{ (k}\Omega\text{)}$$

(1)

Table 2. Standard R_{SET} Resistor Values

V _{OUT} (V)	R _{SET} (kΩ)	R _{RT} (kΩ)	f _{sw} (kHz)	V _{OUT} (V)	R _{SET} (kΩ)	R _{RT} (kΩ)	f _{sw} (kHz)
0.8	open	1200	650	2.3	0.768	348	1000
0.9	11.8	1200	650	2.4	0.715	348	1000
1.0	5.83	1200	650	2.5	0.673	348	1000
1.1	3.83	1200	650	2.6	0.634	348	1000
1.2	2.87	715	750	2.7	0.604	348	1000
1.3	2.32	715	750	2.8	0.576	348	1000
1.4	1.91	715	750	2.9	0.549	348	1000
1.5	1.65	348	1000	3.0	0.523	348	1000
1.6	1.43	348	1000	3.1	0.499	348	1000
1.7	1.27	348	1000	3.2	0.475	348	1000
1.8	1.15	348	1000	3.3	0.459	348	1000
1.9	1.05	348	1000	3.4	0.442	348	1000
2.0	0.953	348	1000	3.5	0.422	348	1000
2.1	0.845	348	1000	3.6	0.412	348	1000
2.2	0.825	348	1000				

CAPACITOR RECOMMENDATIONS FOR THE LMZ30606 POWER SUPPLY

Capacitor Technologies

Electrolytic, Polymer-Electrolytic Capacitors

When using electrolytic capacitors, high-quality, computer-grade electrolytic capacitors are recommended. Polymer-electrolytic type capacitors are recommended for applications where the ambient operating temperature is less than 0°C. The Sanyo OS-CON capacitor series is suggested due to the lower ESR, higher rated surge, power dissipation, ripple current capability, and small package size. Aluminum electrolytic capacitors provide adequate decoupling over the frequency range of 2 kHz to 150 kHz, and are suitable when ambient temperatures are above 0°C.

Ceramic Capacitors

The performance of aluminum electrolytic capacitors is less effective than ceramic capacitors above 150 kHz. Multilayer ceramic capacitors have a low ESR and a resonant frequency higher than the bandwidth of the regulator. They can be used to reduce the reflected ripple current at the input as well as improve the transient response of the output.

Tantalum, Polymer-Tantalum Capacitors

Polymer-tantalum type capacitors are recommended for applications where the ambient operating temperature is less than 0°C. The Sanyo POSCAP series and Kemet T530 capacitor series are recommended rather than many other tantalum types due to their lower ESR, higher rated surge, power dissipation, ripple current capability, and small package size. Tantalum capacitors that have no stated ESR or surge current rating are not recommended for power applications.

Input Capacitor

The LMZ30606 requires a minimum input capacitance of 47 μF of ceramic capacitance. An additional 220 μF polymer-tantalum capacitor is recommended for applications with transient load requirements. The combined ripple current rating of the input capacitors must be at least 3000 mArms. [Table 4](#) includes a preferred list of capacitors by vendor. For applications where the ambient operating temperature is less than 0°C, an additional 1 μF , X5R or X7R ceramic capacitor placed between VIN and AGND is recommended.

Output Capacitor

The required output capacitance is determined by the output voltage of the LMZ30606. See [Table 3](#) for the amount of required capacitance. The required output capacitance must include at least one 47 μF ceramic capacitor. For applications where the ambient operating temperature is less than 0°C, an additional 100 μF polymer-tantalum capacitor is recommended. When adding additional non-ceramic bulk capacitors, low-ESR devices like the ones recommended in [Table 4](#) are required. The required capacitance above the minimum is determined by actual transient deviation requirements. See [Table 5](#) for typical transient response values for several output voltage, input voltage and capacitance combinations. [Table 4](#) includes a preferred list of capacitors by vendor.

Table 3. Required Output Capacitance

V _{OUT} RANGE (V)		MINIMUM REQUIRED C _{OUT} (μF)
MIN	MAX	
0.8	< 1.8	147 ⁽¹⁾
1.8	< 3.3	100 ⁽²⁾
3.3	3.6	47 ⁽²⁾

(1) Minimum required must include at least 1 x 47 μF ceramic capacitor plus 1 x 100 μF polymer-tantalum capacitor.

(2) Minimum required must include at least 47 μF of ceramic capacitance.

Table 4. Recommended Input/Output Capacitors⁽¹⁾

VENDOR	SERIES	PART NUMBER	CAPACITOR CHARACTERISTICS		
			WORKING VOLTAGE (V)	CAPACITANCE (μF)	ESR ⁽²⁾ (mΩ)
Murata	X5R	GRM32ER61C476K	16	47	2
TDK	X5R	C3225X5R0J107M	6.3	100	2
Murata	X5R	GRM32ER60J107M	6.3	100	2
TDK	X5R	C3225X5R0J476K	6.3	47	2
Murata	X5R	GRM32ER60J476M	6.3	47	2
Sanyo	POSCAP	10TPE220ML	10	220	25
Kemet	T520	T520V107M010ASE025	10	100	25
Sanyo	POSCAP	6TPE100MPB	6.3	100	25
Sanyo	POSCAP	2R5TPE220M7	2.5	220	7
Kemet	T530	T530D227M006ATE006	6.3	220	6
Kemet	T530	T530D337M006ATE010	6.3	330	10
Sanyo	POSCAP	2TPF330M6	2.0	330	6
Sanyo	POSCAP	6TPE330MFL	6.3	330	15

(1) Capacitor Supplier Verification

Please verify availability of capacitors identified in this table.

RoHS, Lead-free and Material Details

Please consult capacitor suppliers regarding material composition, RoHS status, lead-free status, and manufacturing process requirements.

(2) Maximum ESR @ 100kHz, 25°C.
Transient Response
Table 5. Output Voltage Transient Response

C _{IN1} = 1 x 47 μF CERAMIC, C _{IN2} = 220 μF POLYMER-TANTALUM						
V _{OUT} (V)	V _{IN} (V)	C _{OUT1} Ceramic	C _{OUT2} BULK	VOLTAGE DEVIATION (mV)		RECOVERY TIME (μs)
				2 A LOAD STEP, (1 A/μs)	3 A LOAD STEP, (1 A/μs)	
0.8	3.3	47 μF	330 μF	35	45	60
		47 μF	470 μF	30	40	60
	5	47 μF	330 μF	30	40	60
		47 μF	470 μF	25	35	60
1.2	3.3	47 μF	330 μF	45	65	60
		47 μF	470 μF	40	60	60
	5	47 μF	330 μF	40	65	60
		47 μF	470 μF	35	60	60
1.8	3.3	47 μF	220 μF	65	90	70
		47 μF	330 μF	60	85	70
	5	47 μF	220 μF	60	85	70
		47 μF	330 μF	50	75	70
2.5	5	3x 47 μF	-	95	150	70
		3x 47 μF	100 μF	85	125	70
3.3	5	3x 47 μF	-	120	180	70
		3x 47 μF	100 μF	100	150	70

Transient Waveforms

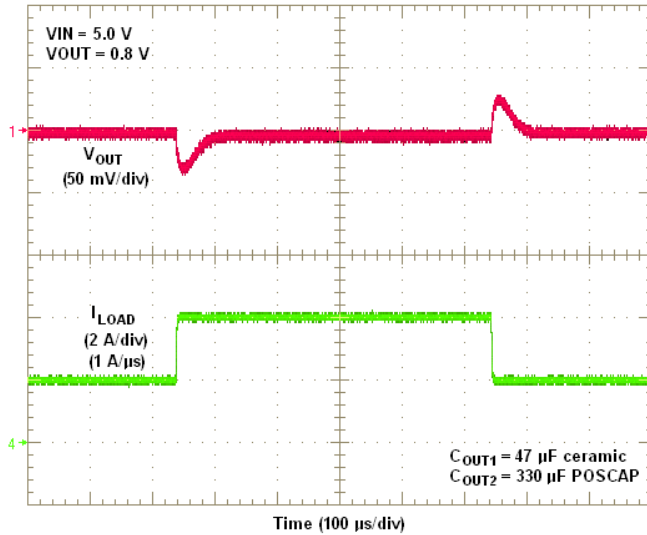

Figure 11. VIN = 5V, VOUT = 0.8V, 2A Load Step

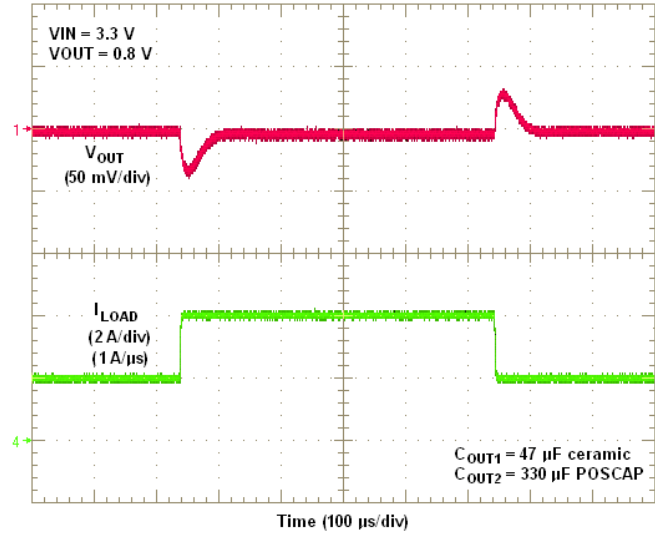

Figure 12. VIN = 3.3V, VOUT = 0.8V, 2A Load Step

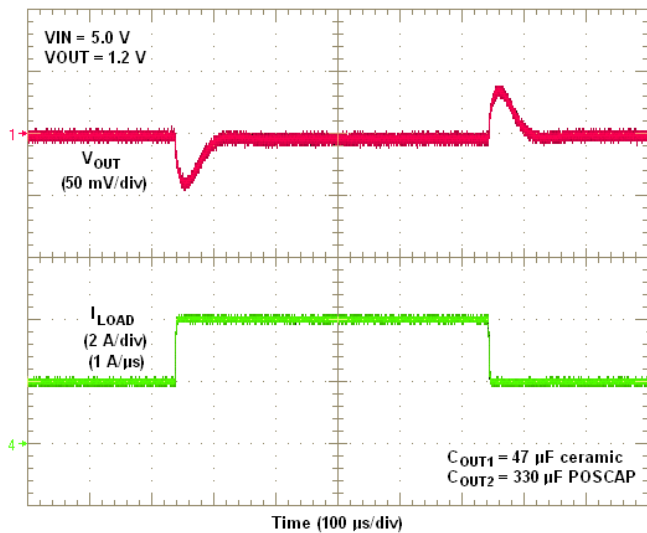

Figure 13. VIN = 5V, VOUT = 1.2V, 2A Load Step

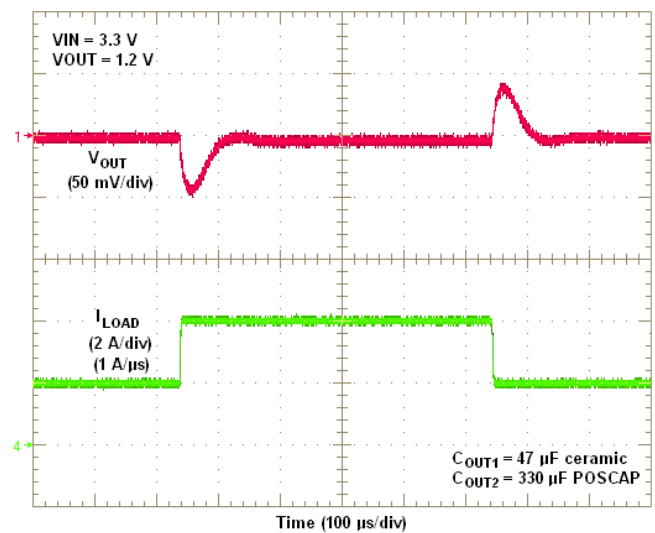

Figure 14. VIN = 3.3V, VOUT = 1.2V, 2A Load Step

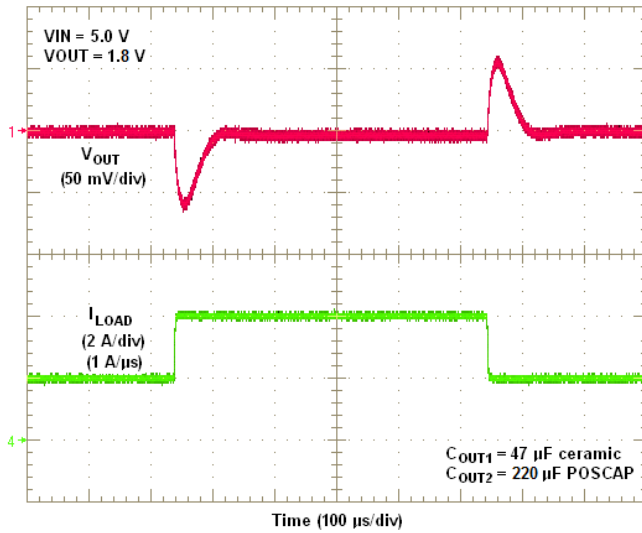

Figure 15. VIN = 5V, VOUT = 1.8V, 2A Load Step

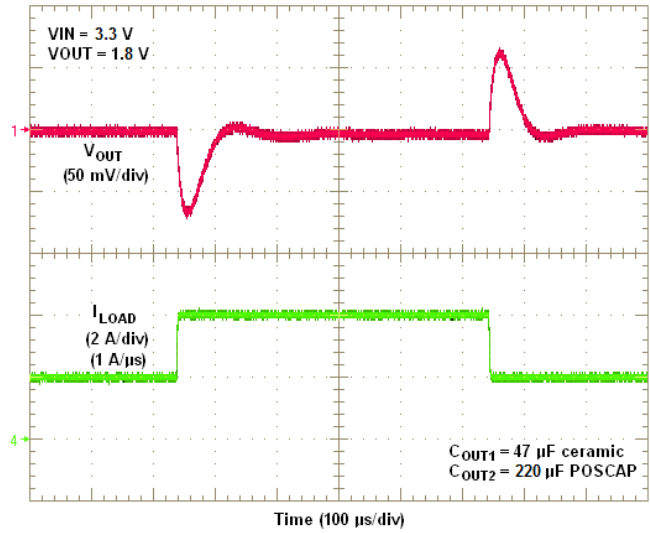

Figure 16. VIN = 3.3V, VOUT = 1.8V, 2A Load Step

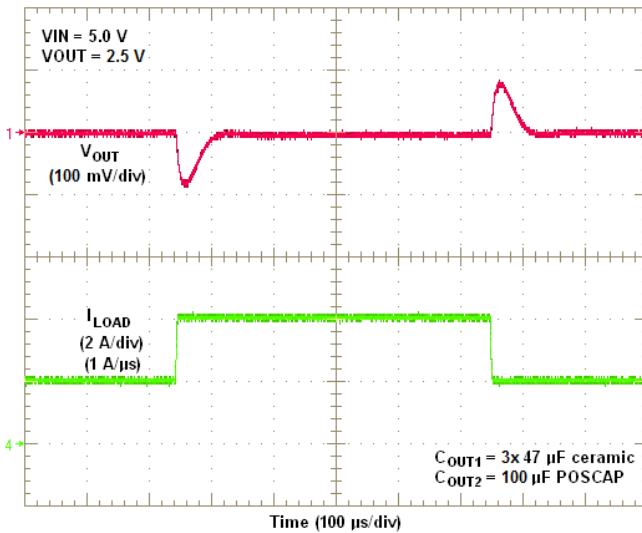

Figure 17. VIN = 5V, VOUT = 2.5V, 2A Load Step

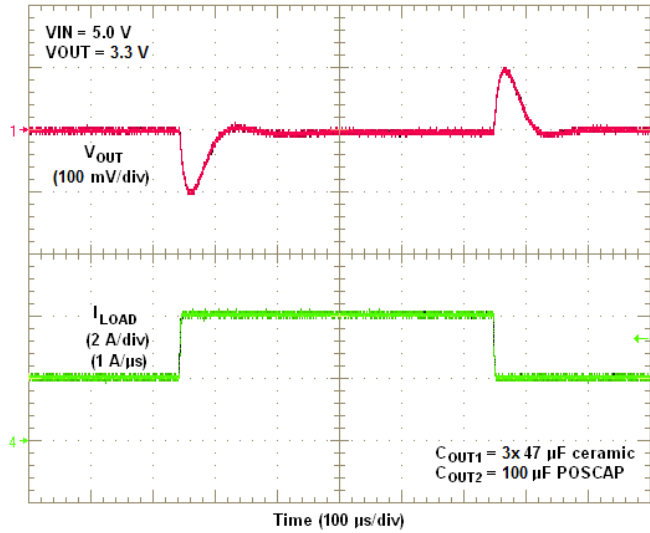

Figure 18. VIN = 5V, VOUT = 3.3V, 2A Load Step

Application Schematics

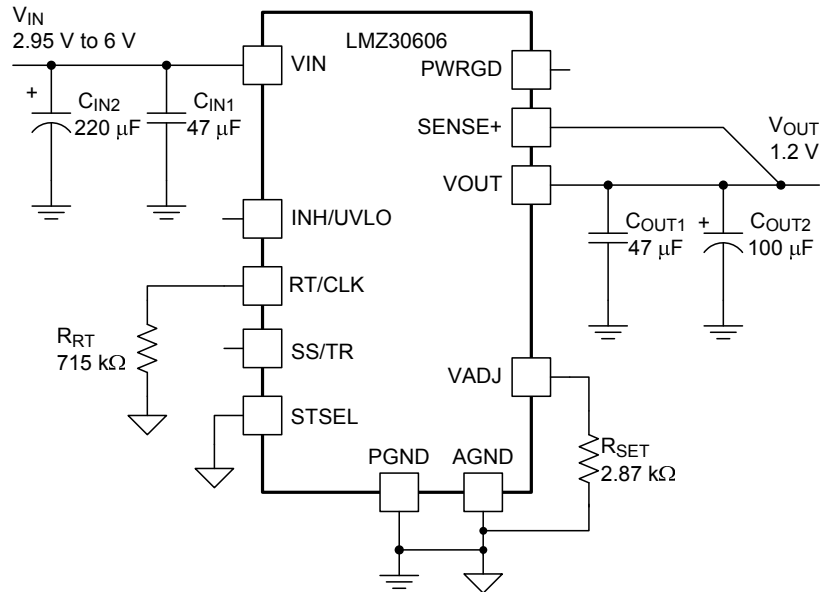

Figure 19. Typical Schematic
VIN = 2.95 V to 6.0 V, VOUT = 1.2 V

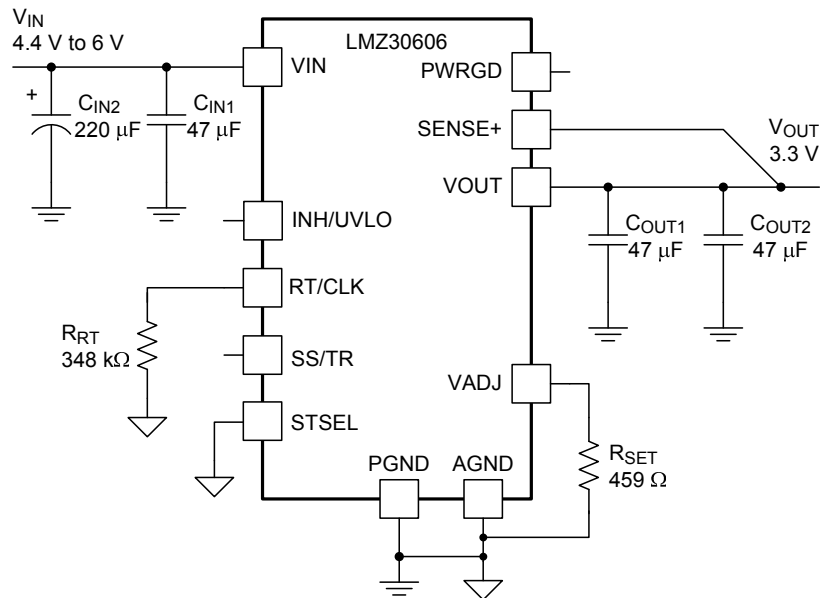

Figure 20. Typical Schematic
VIN = 4.4 V to 6.0 V, VOUT = 3.3 V

Power Good (PWRGD)

The PWRGD pin is an open drain output. Once the voltage on the SENSE+ pin is between 93% and 107% of the set voltage, the PWRGD pin pull-down is released and the pin floats. The recommended pull-up resistor value is between 10 k Ω and 100 k Ω to a voltage source that is 6 V or less. The PWRGD pin is in a defined state once VIN is greater than 1.2 V, but with reduced current sinking capability. The PWRGD pin achieves full current sinking capability once the VIN pin is above 2.95V. Figure 21 shows the PWRGD waveform during power-up. The PWRGD pin is pulled low when the voltage on SENSE+ is lower than 91% or greater than 109% of the nominal set voltage. Also, the PWRGD pin is pulled low if the input UVLO or thermal shutdown is asserted, or if the INH pin is pulled low.

Power-Up Characteristics

When configured as shown in the front page schematic, the LMZ30606 produces a regulated output voltage following the application of a valid input voltage. During the power-up, internal soft-start circuitry slows the rate that the output voltage rises, thereby limiting the amount of in-rush current that can be drawn from the input source. The soft-start circuitry introduces a short time delay from the point that a valid input voltage is recognized. Figure 21 shows the start-up waveforms for a LMZ30606, operating from a 5-V input and with the output voltage adjusted to 1.8 V. The waveform is measured with a 3-A constant current load.

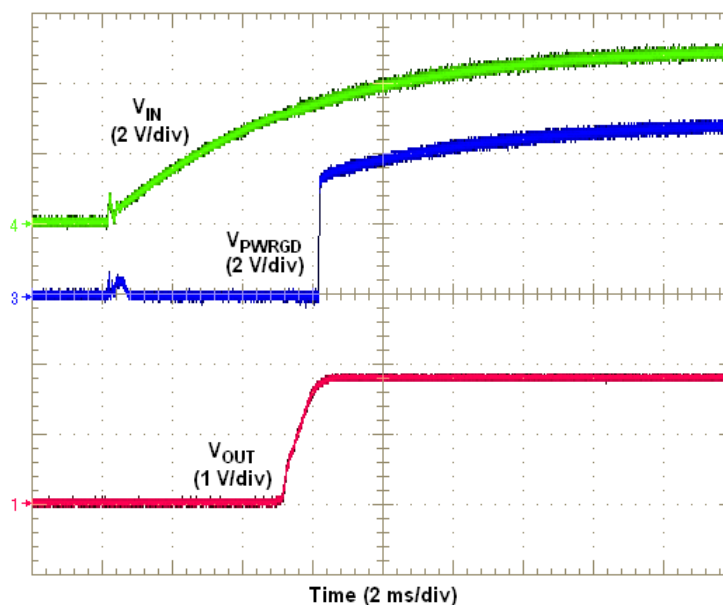

Figure 21. Start-Up Waveforms

Remote Sense

The SENSE+ pin must be connected to V_{OUT} at the load, or at the device pins.

Connecting the SENSE+ pin to V_{OUT} at the load improves the load regulation performance of the device by allowing it to compensate for any I-R voltage drop between its output pins and the load. An I-R drop is caused by the high output current flowing through the small amount of pin and trace resistance. This should be limited to a maximum of 300 mV.

NOTE

The remote sense feature is not designed to compensate for the forward drop of nonlinear or frequency dependent components that may be placed in series with the converter output. Examples include OR-ing diodes, filter inductors, ferrite beads, and fuses. When these components are enclosed by the SENSE+ connection, they are effectively placed inside the regulation control loop, which can adversely affect the stability of the regulator.

Output On/Off Inhibit (INH)

The INH pin provides electrical on/off control of the device. Once the INH pin voltage exceeds the threshold voltage, the device starts operation. If the INH pin voltage is pulled below the threshold voltage, the regulator stops switching and enters low quiescent current state.

The INH pin has an internal pull-up current source, allowing the user to float the INH pin for enabling the device. If an application requires controlling the INH pin, use an open drain/collector device, or a suitable logic gate to interface with the pin. Do not place an external pull-up resistor on this pin. Figure 22 shows the typical application of the inhibit function.

Turning Q1 on applies a low voltage to the inhibit control (INH) pin and disables the output of the supply, as shown in Figure 23. If Q1 is turned off, the supply executes a soft-start power-up sequence, as shown in Figure 24. The waveforms were measured with a 3-A constant current load.

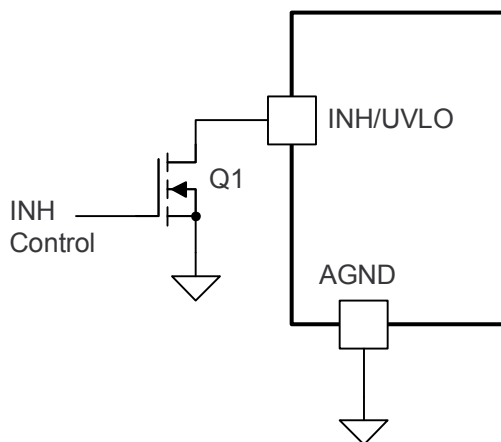

Figure 22. Typical Inhibit Control

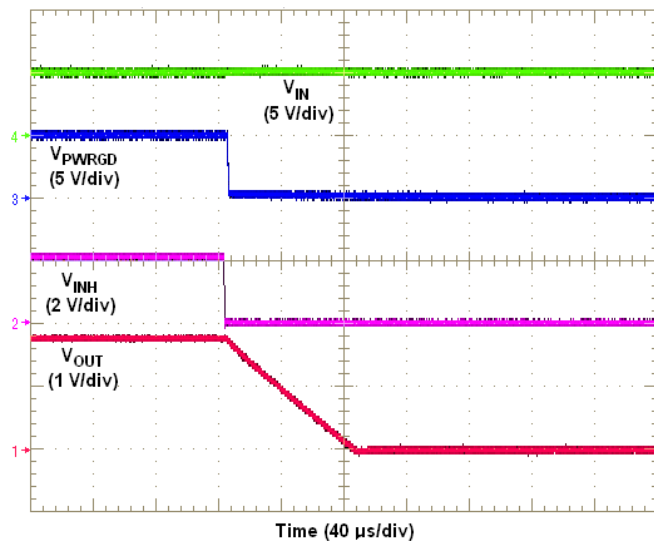

Figure 23. Inhibit Turn-Off

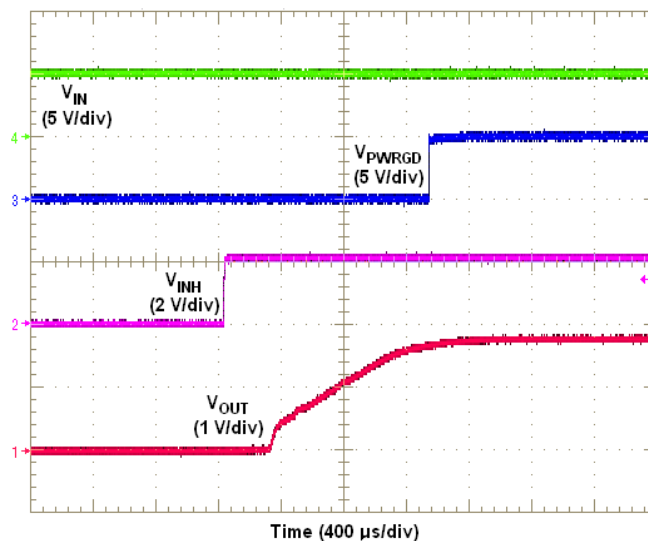

Figure 24. Inhibit Turn-On

Slow Start (SS/TR)

Connecting the STSEL pin to AGND and leaving SS/TR pin open enables the internal SS capacitor with a slow start interval of approximately 1.1 ms. Adding additional capacitance between the SS pin and AGND increases the slow start time. Table 6 shows an additional SS capacitor connected to the SS/TR pin and the STSEL pin connected to AGND. See Table 6 below for SS capacitor values and timing interval.

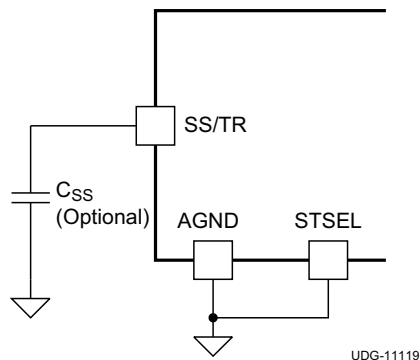

Figure 25. Slow-Start Capacitor (C_{SS}) and STSEL Connection

Table 6. Slow-Start Capacitor Values and Slow-Start Time

C _{SS} (pF)	open	2200	4700	10000	15000	22000	25000
SS Time (msec)	1.1	1.9	2.8	4.6	6.4	8.8	9.8

Overcurrent Protection

For protection against load faults, the LMZ30606 uses current limiting. The device is protected from overcurrent conditions by cycle-by-cycle current limiting and frequency foldback. During an overcurrent condition the output current is limited and the output voltage is reduced, as shown in Figure 26. When the overcurrent condition is removed, the output voltage returns to the established voltage, as shown in Figure 27.

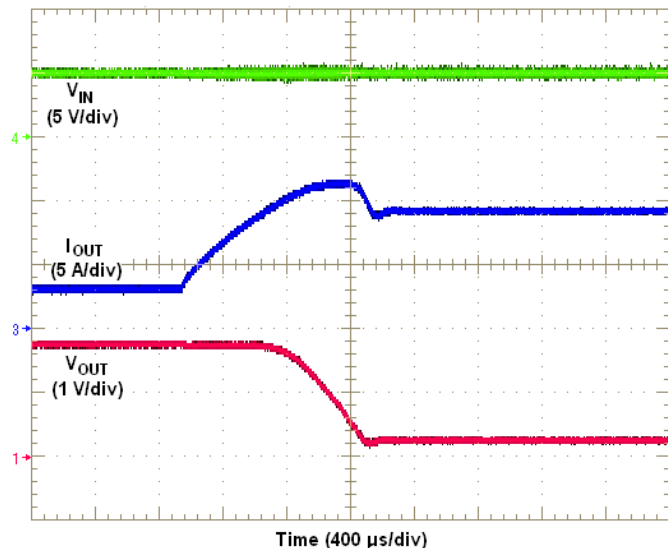

Figure 26. Overcurrent Limiting

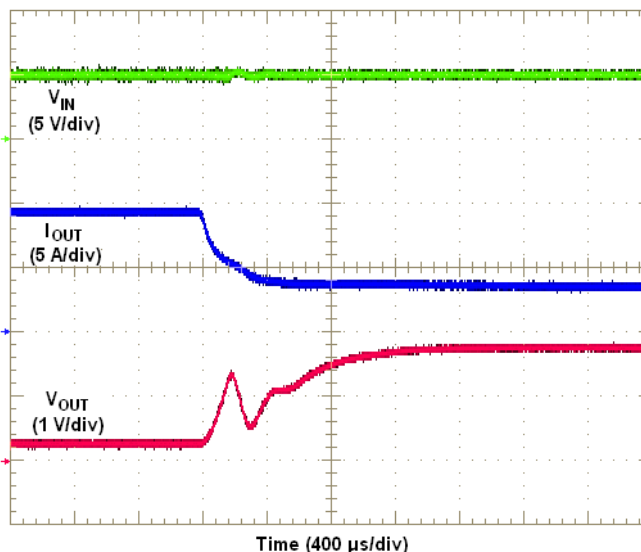

Figure 27. Removal of Overcurrent Condition

Synchronization (CLK)

An internal phase locked loop (PLL) has been implemented to allow synchronization between 500 kHz and 2 MHz, and to easily switch from RT mode to CLK mode. To implement the synchronization feature, connect a square wave clock signal to the RT/CLK pin with a minimum pulse width of 75 ns. The maximum clock pulse width must be calculated using Equation 2. The clock signal amplitude must transition lower than 0.4 V and higher than 2.2 V. The start of the switching cycle is synchronized to the falling edge of RT/CLK pin. Applications requiring both RT mode and CLK mode, configure the device as shown in Figure 28.

Before the external clock is present, the device works in RT mode and the switching frequency is set by the RT resistor (R_{RT}). When the external clock is present, the CLK mode overrides the RT mode. The device switches from RT mode to CLK mode and the RT/CLK pin becomes high impedance as the PLL starts to lock onto the frequency of the external clock. The device will lock to the external clock frequency approximately 15 μ s after a valid clock signal is present. It is not recommended to switch from CLK mode back to RT mode because the internal switching frequency drops to a lower frequency before returning to the switching frequency set by the RT resistor.

$$\text{CLK_PW}_{\text{MAX}} = \frac{0.75 \times \left(1 - \frac{V_{\text{OUT}}}{V_{\text{IN}(\text{min})}} \right)}{f_{\text{SW}}} \quad (2)$$

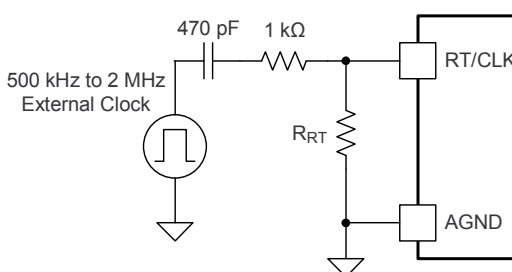

Figure 28. CLK/RT Configuration

Select the synchronization frequency based on the output voltages of the devices being synchronized. Table 7 shows the allowable V_{OUT} range for a given switching frequency when operating from a typical 5 V bus and a typical 3.3 V bus. For the most optimal solution, synchronize to a frequency in the center of the allowable frequency range. For example, an application requires synchronizing three LMZ30606 devices with output voltages of 1.2V, 1.8V, and 3.3V, all powered from $V_{\text{IN}} = 5\text{V}$. Table 7 shows that all three output voltages can be synchronized to any frequency between 600 kHz to 1 MHz. For the most optimal solution, choose 800 kHz as the synchronization frequency. (Values included in the table are based on a resistive load.)

Table 7. Synchronization Frequency vs Output Voltage

SYNCHRONIZATION FREQUENCY (kHz)	R_{RT} (k Ω)	$V_{\text{IN}} = 5\text{V} (+/- 10\%)$		$V_{\text{IN}} = 3.3\text{V} (+/- 5\%)$	
		V_{OUT} RANGE (V)		V_{OUT} RANGE (V)	
		MIN	MAX	MIN	MAX
500	open	0.8	1.8	0.8	2.5
550	3400	0.8	2.2	0.8	2.5
600	1800	0.8	3.3	0.8	2.5
650	1200	0.8	3.6	0.8	2.5
700	887	0.8	3.6	0.8	2.5
750	715	0.9	3.6	0.8	2.5
800	590	0.9	3.6	0.8	2.5
850	511	1.0	3.6	0.8	2.5
900	442	1.0	3.6	0.8	2.5
950	392	1.1	3.6	0.8	2.5
1000	348	1.1	3.6	0.8	2.5
1250	232	1.4	3.6	0.9	2.4
1500	174	1.7	3.5	1.1	2.3
1750	137	2.0	3.4	1.3	2.3
2000	113	2.2	3.3	1.4	2.2

Sequencing (SS/TR)

Many of the common power supply sequencing methods can be implemented using the SS/TR, INH and PWRGD pins. The sequential method is illustrated in Figure 29 using two LMZ30606 devices. The PWRGD pin of the first device is coupled to the INH pin of the second device which enables the second power supply once the primary supply reaches regulation. Figure 30 shows sequential turn-on waveforms of two LMZ30606 devices.

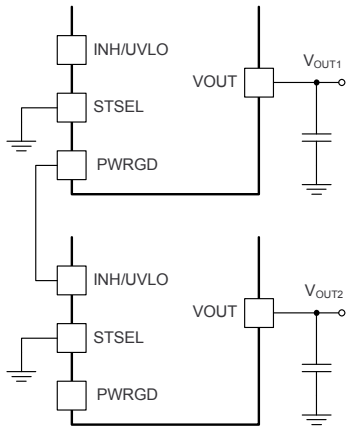

Figure 29. Sequencing Schematic

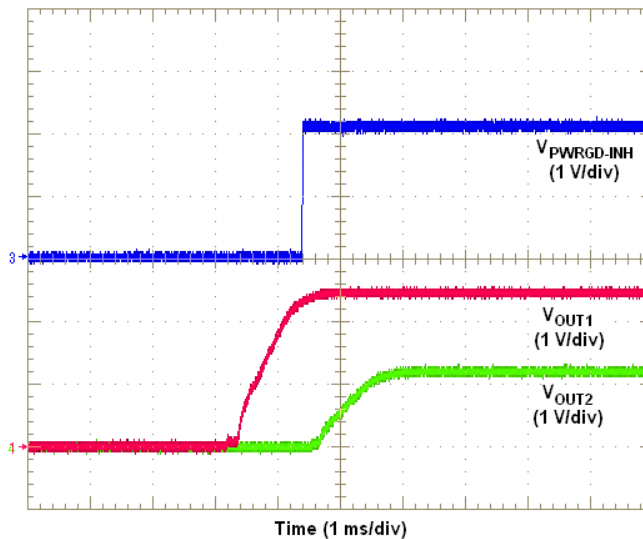

Figure 30. Sequencing Waveforms

Simultaneous power supply sequencing can be implemented by connecting the resistor network of R1 and R2 shown in Figure 31 to the output of the power supply that needs to be tracked or to another voltage reference source. Figure 32 shows simultaneous turn-on waveforms of two LMZ30606 devices. Use Equation 3 and Equation 4 to calculate the values of R1 and R2.

$$R1 = \frac{(V_{OUT2} \times 12.6)}{0.799} \text{ (k}\Omega\text{)}$$

(3)

$$R2 = \frac{0.799 \times R1}{(V_{OUT2} - 0.799)} \text{ (k}\Omega\text{)}$$

(4)

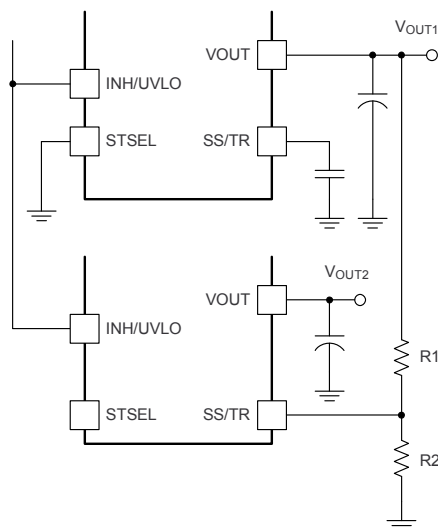

Figure 31. Simultaneous Tracking Schematic

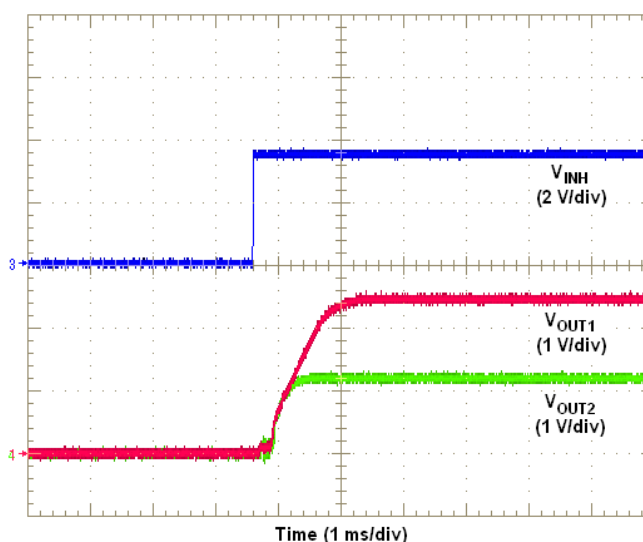

Figure 32. Simultaneous Tracking Waveforms

Programmable Undervoltage Lockout (UVLO)

The LMZ30606 implements internal UVLO circuitry on the VIN pin. The device is disabled when the VIN pin voltage falls below the internal VIN UVLO threshold. The internal VIN UVLO rising threshold is 3.135 V(max) with a typical hysteresis of 300 mV.

If an application requires a higher UVLO threshold on the VIN pin, the UVLO pin can be configured as shown in [Figure 33](#). [Table 8](#) lists standard values for R_{UVLO} to adjust the VIN UVLO voltage up.

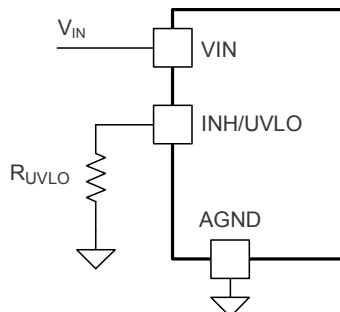

Figure 33. Adjustable VIN UVLO

Table 8. Standard Resistor values for Adjusting VIN UVLO

VIN UVLO (V) (typ)	3.25	3.5	3.75	4.0	4.25	4.5	4.75
R_{UVLO} (k Ω)	294	133	86.6	63.4	49.9	42.2	35.7
Hysteresis (mV)	325	335	345	355	365	375	385

Thermal Shutdown

The internal thermal shutdown circuitry forces the device to stop switching if the junction temperature exceeds 170°C typically. The device reinitiates the power up sequence when the junction temperature drops below 150°C typically.

EMI

The LMZ30606 is compliant with EN55022 Class B radiated emissions. [Figure 34](#) and [Figure 35](#) show typical examples of radiated emissions plots for the LMZ30606 operating from 5V and 3.3V respectively. Both graphs include the plots of the antenna in the horizontal and vertical positions.

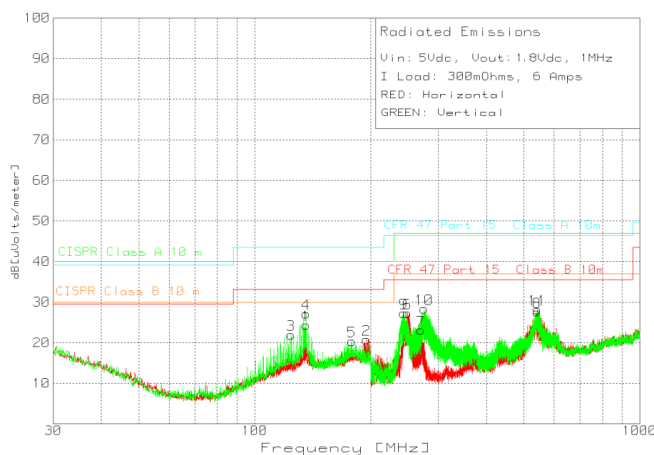

Figure 34. Radiated Emissions 5-V Input, 1.8-V Output, 6-A Load (EN55022 Class B)

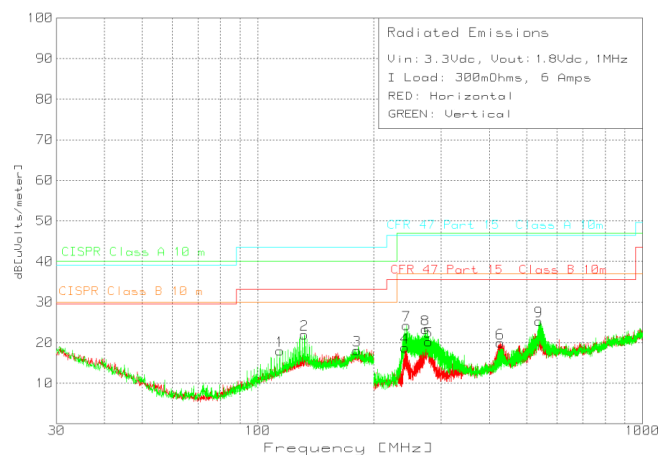

Figure 35. Radiated Emissions 3.3-V Input, 1.8-V Output, 6-A Load (EN55022 Class B)

Layout Considerations

To achieve optimal electrical and thermal performance, an optimized PCB layout is required. Figure 36, shows a typical PCB layout. Some considerations for an optimized layout are:

- Use large copper areas for power planes (VIN, VOUT, and PGND) to minimize conduction loss and thermal stress.
- Place ceramic input and output capacitors close to the module pins to minimize high frequency noise.
- Locate additional output capacitors between the ceramic capacitor and the load.
- Place a dedicated AGND copper area beneath the LMZ30606.
- Connect the AGND and PGND copper area at one point; directly at the pin 37 PowerPad using multiple vias.
- Place R_{SET} , R_{RT} , and C_{SS} as close as possible to their respective pins.
- Use multiple vias to connect the power planes to internal layers.

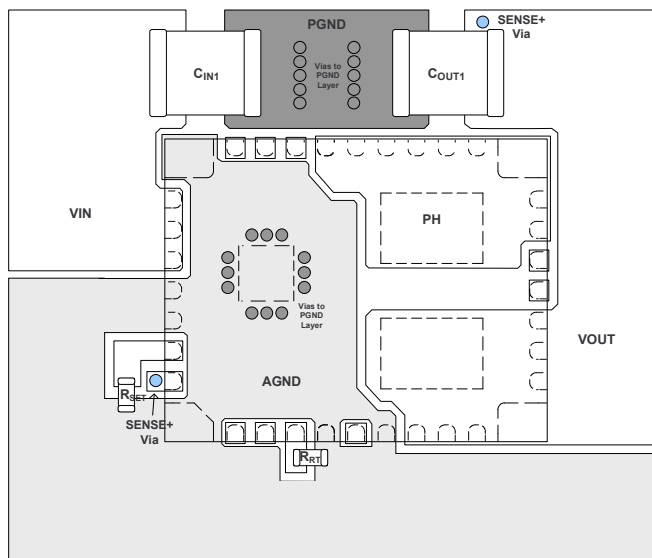

Figure 36. Typical Top-Layer Recommended Layout

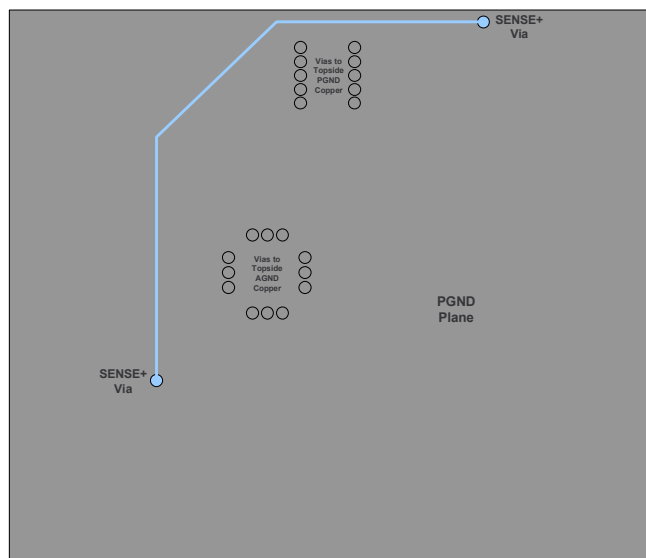

Figure 37. Typical PGND-Layer Recommended Layout

PACKAGING INFORMATION

Orderable Device	Status (1)	Package Type	Package Drawing	Pins	Package Qty	Eco Plan (2)	Lead/Ball Finish	MSL Peak Temp (3)	Op Temp (°C)	Device Marking (4/5)	Samples
LMZ30606RKGR	PREVIEW	B1QFN	RKG	39	500	TBD	Call TI	Call TI	-40 to 85	LMZ30606	
LMZ30606RKGT	PREVIEW	B1QFN	RKG	39	250	TBD	Call TI	Call TI	-40 to 85	LMZ30606	

(1) The marketing status values are defined as follows:

ACTIVE: Product device recommended for new designs.

LIFEBUY: TI has announced that the device will be discontinued, and a lifetime-buy period is in effect.

NRND: Not recommended for new designs. Device is in production to support existing customers, but TI does not recommend using this part in a new design.

PREVIEW: Device has been announced but is not in production. Samples may or may not be available.

OBSOLETE: TI has discontinued the production of the device.

(2) Eco Plan - The planned eco-friendly classification: Pb-Free (RoHS), Pb-Free (RoHS Exempt), or Green (RoHS & no Sb/Br) - please check <http://www.ti.com/productcontent> for the latest availability information and additional product content details.

TBD: The Pb-Free/Green conversion plan has not been defined.

Pb-Free (RoHS): TI's terms "Lead-Free" or "Pb-Free" mean semiconductor products that are compatible with the current RoHS requirements for all 6 substances, including the requirement that lead not exceed 0.1% by weight in homogeneous materials. Where designed to be soldered at high temperatures, TI Pb-Free products are suitable for use in specified lead-free processes.

Pb-Free (RoHS Exempt): This component has a RoHS exemption for either 1) lead-based flip-chip solder bumps used between the die and package, or 2) lead-based die adhesive used between the die and leadframe. The component is otherwise considered Pb-Free (RoHS compatible) as defined above.

Green (RoHS & no Sb/Br): TI defines "Green" to mean Pb-Free (RoHS compatible), and free of Bromine (Br) and Antimony (Sb) based flame retardants (Br or Sb do not exceed 0.1% by weight in homogeneous material)

(3) MSL, Peak Temp. -- The Moisture Sensitivity Level rating according to the JEDEC industry standard classifications, and peak solder temperature.

(4) There may be additional marking, which relates to the logo, the lot trace code information, or the environmental category on the device.

(5) Multiple Device Markings will be inside parentheses. Only one Device Marking contained in parentheses and separated by a "~" will appear on a device. If a line is indented then it is a continuation of the previous line and the two combined represent the entire Device Marking for that device.

Important Information and Disclaimer: The information provided on this page represents TI's knowledge and belief as of the date that it is provided. TI bases its knowledge and belief on information provided by third parties, and makes no representation or warranty as to the accuracy of such information. Efforts are underway to better integrate information from third parties. TI has taken and continues to take reasonable steps to provide representative and accurate information but may not have conducted destructive testing or chemical analysis on incoming materials and chemicals. TI and TI suppliers consider certain information to be proprietary, and thus CAS numbers and other limited information may not be available for release.

In no event shall TI's liability arising out of such information exceed the total purchase price of the TI part(s) at issue in this document sold by TI to Customer on an annual basis.



MECHANICAL DATA

RKG (R-PB1QFN-N39)

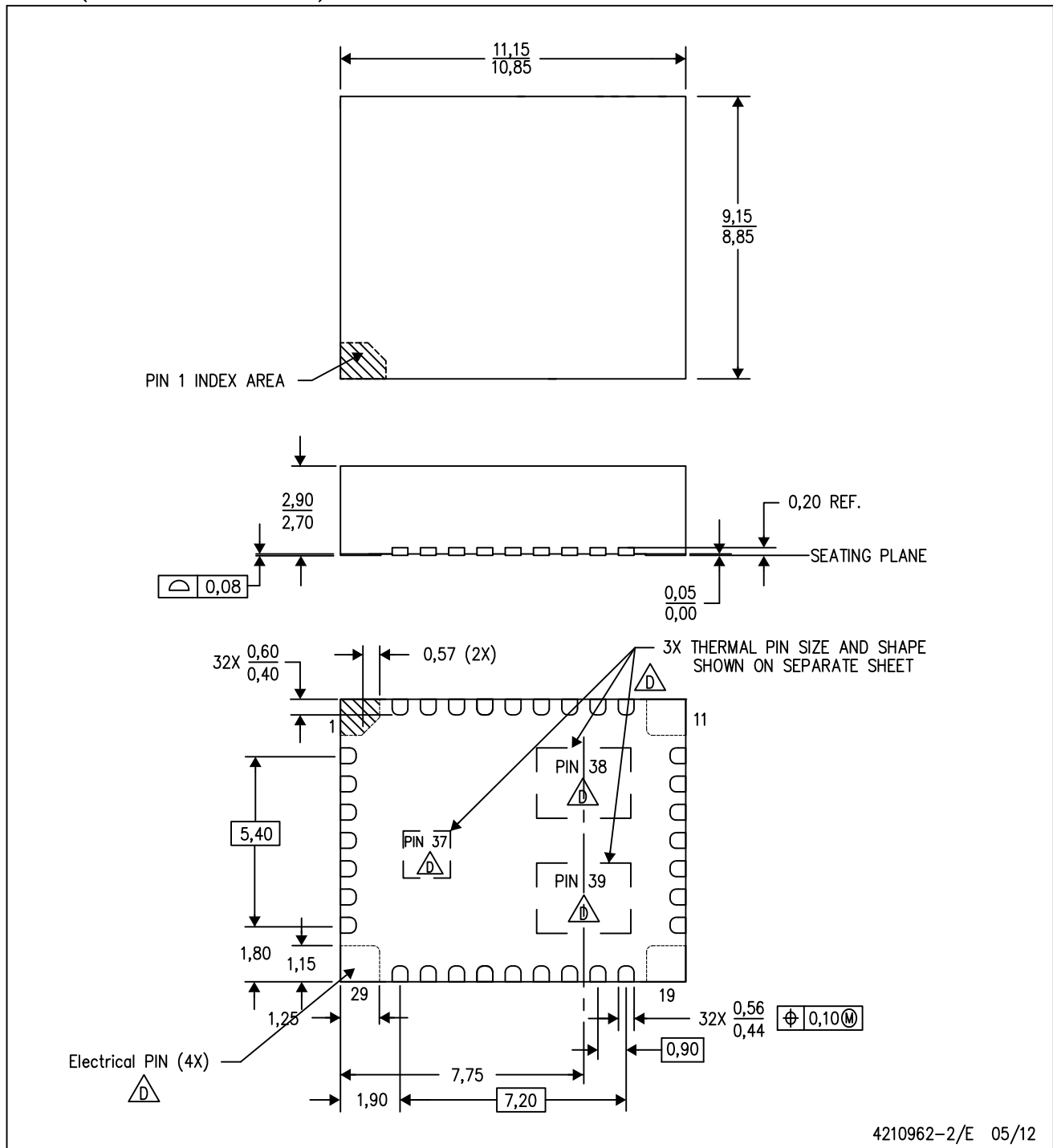
PLASTIC QUAD FLATPACK NO-LEAD



4210962-2/E 05/12

- NOTES:
- A. All linear dimensions are in millimeters. Dimensioning and tolerancing per ASME Y14.5M-1994.
 - B. This drawing is subject to change without notice.
 - C. Quad Flatpack, No-leads (QFN) package configuration.
 -  D. The package thermal pad must be soldered to the board for thermal and mechanical performance.
 - E. See the additional figure in the Product Data Sheet for details regarding the exposed thermal pad features and dimensions.
 -  F. The package thermal performance may be enhanced by bonding the thermal pad to an external thermal plane.

IMPORTANT NOTICE

Texas Instruments Incorporated and its subsidiaries (TI) reserve the right to make corrections, enhancements, improvements and other changes to its semiconductor products and services per JESD46, latest issue, and to discontinue any product or service per JESD48, latest issue. Buyers should obtain the latest relevant information before placing orders and should verify that such information is current and complete. All semiconductor products (also referred to herein as "components") are sold subject to TI's terms and conditions of sale supplied at the time of order acknowledgment.

TI warrants performance of its components to the specifications applicable at the time of sale, in accordance with the warranty in TI's terms and conditions of sale of semiconductor products. Testing and other quality control techniques are used to the extent TI deems necessary to support this warranty. Except where mandated by applicable law, testing of all parameters of each component is not necessarily performed.

TI assumes no liability for applications assistance or the design of Buyers' products. Buyers are responsible for their products and applications using TI components. To minimize the risks associated with Buyers' products and applications, Buyers should provide adequate design and operating safeguards.

TI does not warrant or represent that any license, either express or implied, is granted under any patent right, copyright, mask work right, or other intellectual property right relating to any combination, machine, or process in which TI components or services are used. Information published by TI regarding third-party products or services does not constitute a license to use such products or services or a warranty or endorsement thereof. Use of such information may require a license from a third party under the patents or other intellectual property of the third party, or a license from TI under the patents or other intellectual property of TI.

Reproduction of significant portions of TI information in TI data books or data sheets is permissible only if reproduction is without alteration and is accompanied by all associated warranties, conditions, limitations, and notices. TI is not responsible or liable for such altered documentation. Information of third parties may be subject to additional restrictions.

Resale of TI components or services with statements different from or beyond the parameters stated by TI for that component or service voids all express and any implied warranties for the associated TI component or service and is an unfair and deceptive business practice. TI is not responsible or liable for any such statements.

Buyer acknowledges and agrees that it is solely responsible for compliance with all legal, regulatory and safety-related requirements concerning its products, and any use of TI components in its applications, notwithstanding any applications-related information or support that may be provided by TI. Buyer represents and agrees that it has all the necessary expertise to create and implement safeguards which anticipate dangerous consequences of failures, monitor failures and their consequences, lessen the likelihood of failures that might cause harm and take appropriate remedial actions. Buyer will fully indemnify TI and its representatives against any damages arising out of the use of any TI components in safety-critical applications.

In some cases, TI components may be promoted specifically to facilitate safety-related applications. With such components, TI's goal is to help enable customers to design and create their own end-product solutions that meet applicable functional safety standards and requirements. Nonetheless, such components are subject to these terms.

No TI components are authorized for use in FDA Class III (or similar life-critical medical equipment) unless authorized officers of the parties have executed a special agreement specifically governing such use.

Only those TI components which TI has specifically designated as military grade or "enhanced plastic" are designed and intended for use in military/aerospace applications or environments. Buyer acknowledges and agrees that any military or aerospace use of TI components which have **not** been so designated is solely at the Buyer's risk, and that Buyer is solely responsible for compliance with all legal and regulatory requirements in connection with such use.

TI has specifically designated certain components as meeting ISO/TS16949 requirements, mainly for automotive use. In any case of use of non-designated products, TI will not be responsible for any failure to meet ISO/TS16949.

Products

Audio	www.ti.com/audio
Amplifiers	amplifier.ti.com
Data Converters	dataconverter.ti.com
DLP® Products	www.dlp.com
DSP	dsp.ti.com
Clocks and Timers	www.ti.com/clocks
Interface	interface.ti.com
Logic	logic.ti.com
Power Mgmt	power.ti.com
Microcontrollers	microcontroller.ti.com
RFID	www.ti-rfid.com
OMAP Applications Processors	www.ti.com/omap
Wireless Connectivity	www.ti.com/wirelessconnectivity

Applications

Automotive and Transportation	www.ti.com/automotive
Communications and Telecom	www.ti.com/communications
Computers and Peripherals	www.ti.com/computers
Consumer Electronics	www.ti.com/consumer-apps
Energy and Lighting	www.ti.com/energy
Industrial	www.ti.com/industrial
Medical	www.ti.com/medical
Security	www.ti.com/security
Space, Avionics and Defense	www.ti.com/space-avionics-defense
Video and Imaging	www.ti.com/video

TI E2E Community

e2e.ti.com